

## Hatch for ceiling panel SD50W

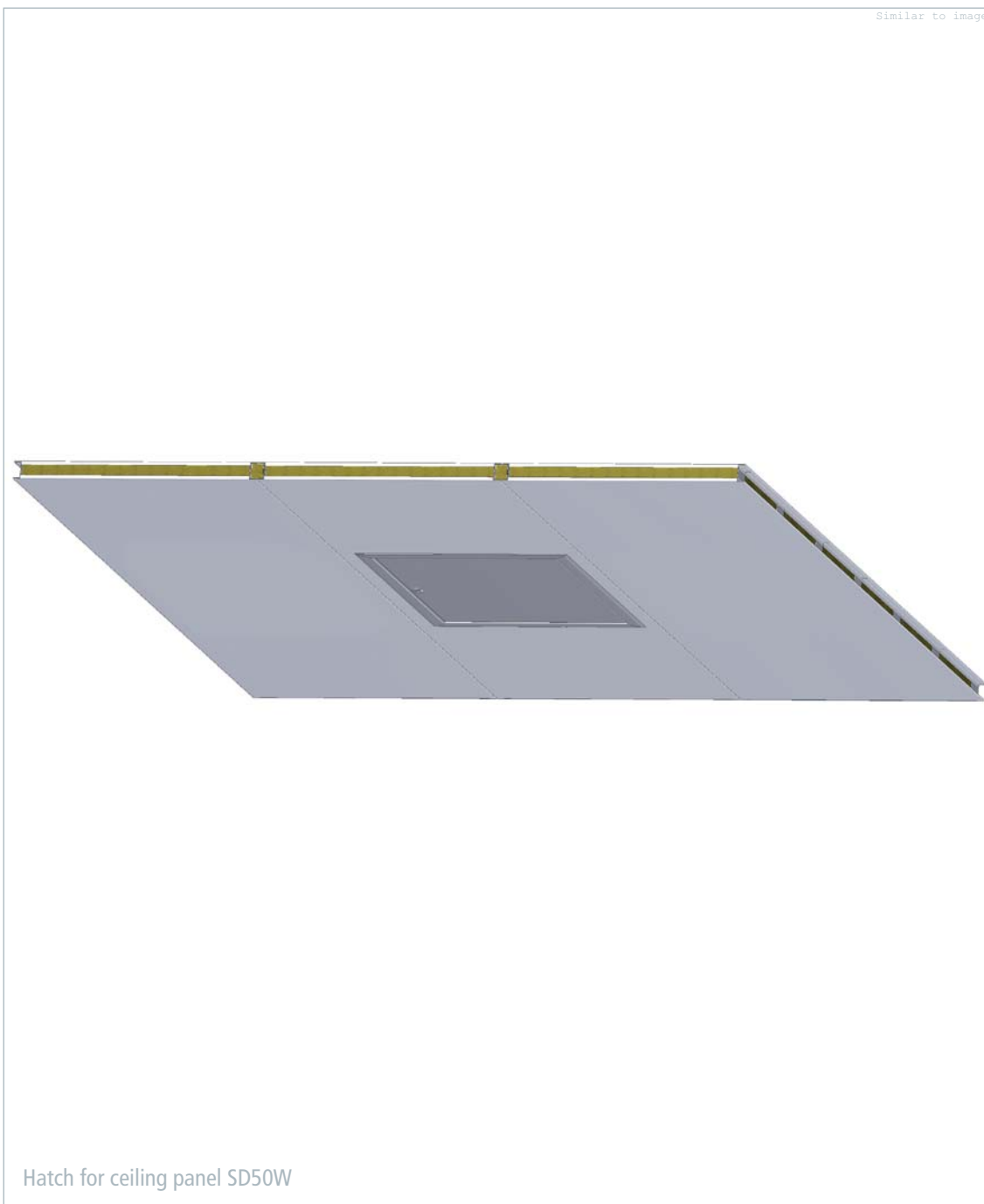

■ The hatch for the SD50W ceiling panel can be used in situations where fire classification of B-15 is stipulated and access to the area above the ceiling is required. The hatch is characterized by its closing mechanism, which is situated in the middle, and the surrounding frame that, in addition to eye-catching aesthetics, enables connection to the neighboring panel. A large variety of surface finishes are available; all of them have a removable protective foil to prevent any damage from occurring during installation. The design of the hatch for ceiling panel SD50W and all components used have been tested and approved according to international standards.

Others

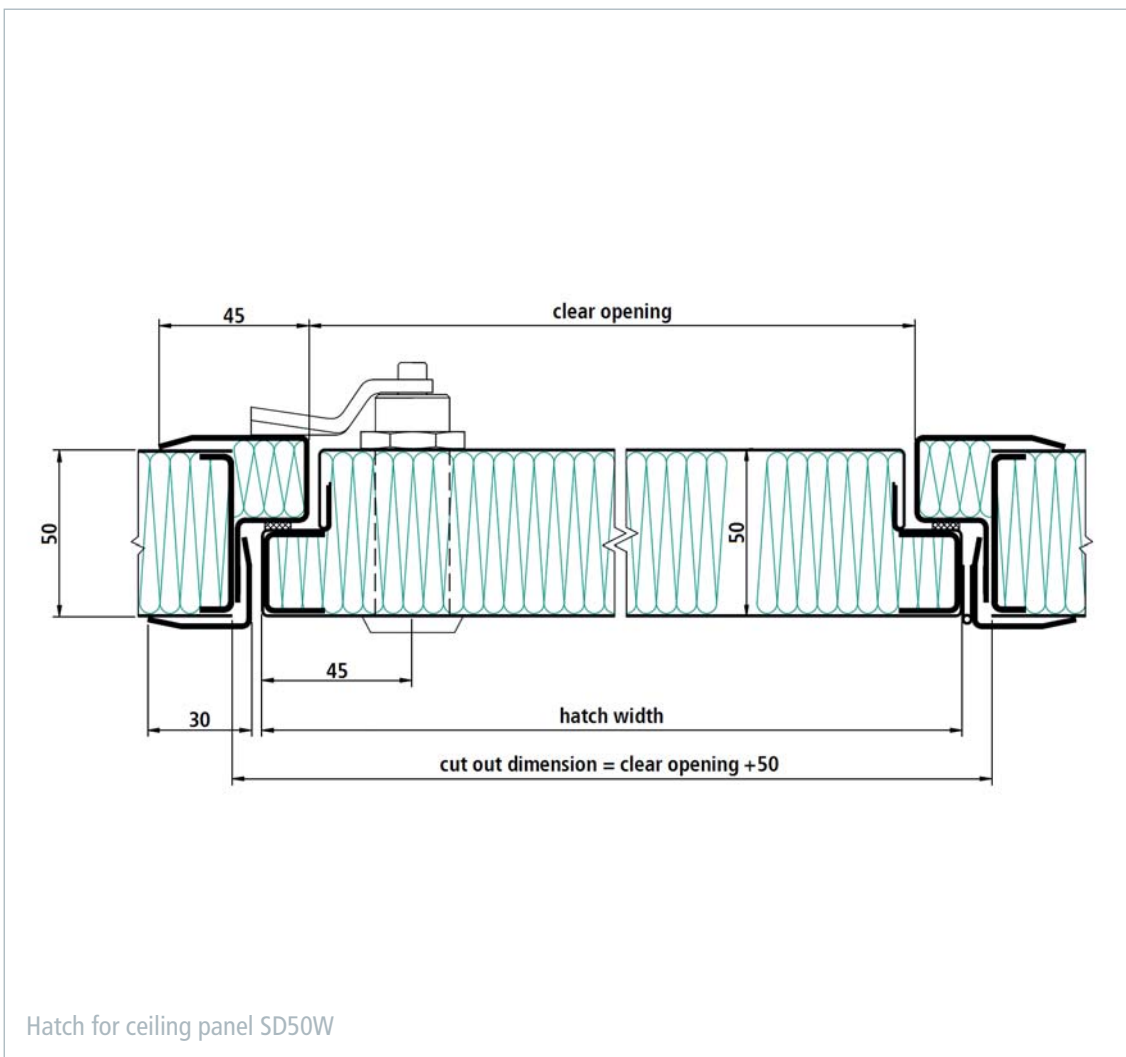

Others

Hatch for ceiling panel SD50W	
Technical data	Steel   Steel
Fire classification	B-15
Element width	max. 500 mm
Element length	max. 700 mm
Thickness of hatch leaf	50 mm
Applicable for	SD50W
Mass per area	---
Density of insulation material	150 kg/m <sup>3</sup>
Coating	PVC foil varnish coated (others on request)
Certification	EC, USCG, RMRS